

 LIGHTNING AUDIO®

# STRIKE®

## AMPLIFIERS

S4.200.2

S4.400.2

S4.600.2

S4.400.4

S4.600.4S

S4.500.1

S4.1000.1D



*Installation & Operation*  
*Installation et fonctionnement*  
*Instalación y operación*  
*Einbau und Betrieb*  
*Installazione e funzionamento*

# INTRODUCTION

## INNOVATE OR DISINTEGRATE

Thank you for purchasing the Lightning Audio Strike Amplifier.

Our customers have come to expect that Lightning Audio pushes the edge in audio. Now we will push the edge in the amplifier and woofer business with high value and high performance models.

If, after reading your manual, you still have questions regarding this product, we recommend that you see your Lightning Audio dealer. If you need further assistance, you can call us direct at 1-888-881-8186. Be sure to have your serial number, model number and the dated proof of purchase available when you call.

The serial number can be found on the outside of the box. Please record it in the space provided below as your permanent record. This will serve as verification of your factory warranty and may become useful in recovering your amplifier if it is ever stolen.

**Serial Number:** \_\_\_\_\_

**Model Number:** \_\_\_\_\_

## TABLE OF CONTENTS

<b>Introduction</b> .....	<b>2</b>	<b>Operation</b> .....	<b>10-11</b>
<b>Safety Instructions</b> .....	<b>3</b>	Adjusting Level .....	10
<b>Design Features</b> .....	<b>3-4</b>	Adjusting Crossover (X-Over) .....	10
<b>Installation</b> .....	<b>4-9</b>	Subsonic Filter (S4.1000.1D Only) .....	10
Installation Considerations .....	4	Strapping Amplifiers	
Mounting Locations .....	5	(S4.1000.1D Only) .....	11
Battery and Charging .....	6	<b>Troubleshooting</b> .....	<b>11</b>
Wiring the System .....	6	<b>Specifications</b> .....	<b>12</b>
Remote Level Control		<b>Limited Warranty Information</b> .....	<b>13</b>
(S4.1000.1D Only) .....	9	<b>International Instructions</b> .....	<b>14</b>
Using Passive Crossovers .....	9		

**NOTE:** Review each section for more detailed information.

# PRACTICE SAFE SOUND™

Continuous exposure to sound pressure levels over 100dB may cause permanent hearing loss. High powered auto sound systems may produce sound pressure levels well over 130dB. Use common sense and practice safe sound.

## SAFETY INSTRUCTIONS

### ⚠️ WARNING

This symbol with “**WARNING**” is intended to alert the user to the presence of important instructions. Failure to heed the instructions will result in severe injury or death.

### ⚠️ CAUTION

This symbol with “**CAUTION**” is intended to alert the user to the presence of important instructions. Failure to heed the instructions can result in injury or unit damage.

⚠️ **CAUTION:** To prevent injury and damage to the unit, please read and follow the instructions in this manual. We want you to have enjoyment from this system, not a headache.

⚠️ **CAUTION** If you feel unsure about installing this system yourself, have it installed by a qualified Lightning Audio technician.

⚠️ **CAUTION** Before installation, disconnect the battery negative (-) terminal to prevent damage to the unit, fire and/or possible injury.

## DESIGN FEATURES

### Power Connections

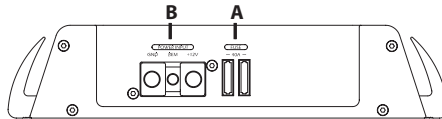

S4.500.1 S4.200.2

S4.400.2 S4.600.2

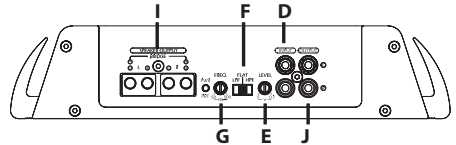
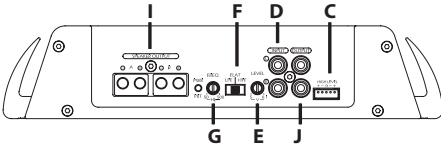

S4.400.4

S4.600.4S

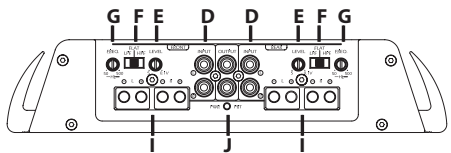
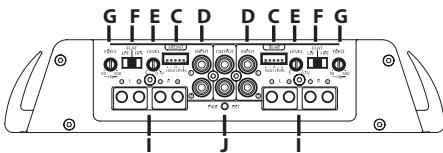

S4.1000.1D

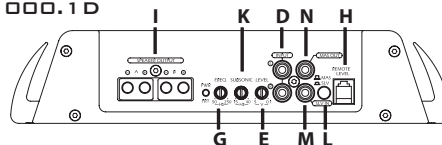

## DESIGN FEATURES

- A. **Power Fuse:** If this Fuse should blow, determine the cause or see your authorized dealer. Never replace the fuse with one of greater value than the original
- B. **Power Connector terminals:** Connects Power, Ground, and Remote
- C. **High Level (Speaker) Inputs:** (Models S4.500.1, S4.200.2 and S4.400.4 Only) The high level inputs use a detachable connector terminated with 20 AWG leads. These inputs should be used if the source unit has only speaker line (high level) outputs and not RCA outputs.
- D. **RCA Input Jacks** – Line Level from Radio Pre-outs: The industry standard RCA jack provides an easy connection for signal level input. They are platinum to resist the signal degradation caused by corrosion.
- E. **Level Control:** The input level control is preset to match the output of most source units. This can be adjusted to match output levels from a variety of source units.
- F. **Crossover Filter Switch:** High for High Pass - Mid-Tweeter.  
Flat for All Pass - Full Range.  
Low for Low Pass - Subs.
- G. **Adjustable Crossover Frequency Control:** 50-500Hz @ 12dB/octave. 50-250Hz Low Pass only on Model S4.1000.1D.
- H. **Remote Level Control:** (Model S4.1000.1D Only) Attenuates Gain set on the amplifier by up to -12dB
- I. **Speaker Connections:** Follow correct polarity, and do not Ground any speaker wires. Do not connect any speaker wires together.
- J. **Pass Thru Outputs:** The Pass-Thru provides a convenient source for daisy-chaining an additional amplifier without running an extra set of RCA cables from the front of the vehicle to the rear amplifier location.
- K. **Subsonic Control:** (Model S4.1000.1D Only) A variable 15-40Hz high pass filter designed to prevent frequencies below the audio range from being applied to the subwoofer from the amplifier. Improving subwoofer performance and power handling.
- L. **Master / Slave Switch:** (Model S4.1000.1D Only) Used to set the amplifier to master or slave when strapping.
- M. **SLV IN (slave):** (Model S4.1000.1D Only) When strapping, this is the slaved amplifier input from the master amplifier.
- N. **MAS OUT (master):** (Model S4.1000.1D Only) When strapping, this is the master amplifier output to the slave amplifier.

## INSTALLATION

### INSTALLATION CONSIDERATIONS

The following is a list of tools needed for installation:

Volt/Ohm Meter

Wire strippers

Wire crimpers

Wire cutters

#2 Phillips screwdriver

Battery post wrench

Hand held drill w/assorted bits

1/8" diameter heatshrink tubing

Assorted connectors

Adequate Length—Power Wire

Adequate Length—Remote Turn-on Wire

Adequate Length—Grounding Wire

# INSTALLATION

This section focuses on some of the vehicle considerations for installing your new Amplifier. Pre-planning your system layout and best wiring routes will save installation time. When deciding on the layout of your new system, be sure that each component will be easily accessible for making adjustments.

 **CAUTION:** If you feel unsure about installing this system yourself, have it installed by a qualified technician.

 **CAUTION:** Before installation, disconnect the battery negative (-) terminal to prevent damage to the unit, fire and/or possible injury.

Before beginning any installation, follow these simple rules:

1. Be sure to carefully read and understand the instructions before attempting to install the unit.
2. For safety, disconnect the negative lead from the battery prior to beginning the installation.
3. For easier assembly, we suggest you run all wires prior to mounting your unit in place.
4. Route all of the RCA cables close together and away from any high current wires.
5. Use high quality connectors for a reliable installation and to minimize signal or power loss.
6. Think before you drill! Be careful not to cut or drill into gas tanks, fuel lines, brake or hydraulic lines, vacuum lines or electrical wiring when working on any vehicle.
7. Never run wires underneath the vehicle. Running the wires inside the vehicle provides the best protection.
8. Avoid running wires over or through sharp edges. Use rubber or plastic grommets to protect any wires routed through metal, especially the firewall.
9. ALWAYS protect the battery and electrical system from damage with proper fusing. Install the appropriate fuse holder and fuse on the +12V power wire within 18" (45.7 cm) of the battery terminal.
10. When grounding to the chassis of the vehicle, scrape all paint from the metal to ensure a good, clean ground connection. Grounding connections should be as short as possible and always be connected to metal that is welded to the main body, or chassis, of the vehicle.

## MOUNTING LOCATIONS

The mounting position of your amplifier will have a great effect on the sound and performance produced.

### ***Engine Compartment***

Never mount this unit in the engine compartment. Mounting the unit in the engine compartment will void your warranty.

### ***Passenger Compartment Mounting***

Mounting the amplifier in the passenger compartment will work as long as you provide a sufficient amount of air for the amplifier to cool itself. If you are going to mount the amplifier under the seat of the vehicle, you must have at least 1" (2.54cm) of air gap around the amplifier's heatsink.

Mounting the amplifier with less than 1" (2.54cm) of air gap around the amplifier's heatsink in the passenger compartment will not provide proper cooling and will severely affect the performance of the amplifier and is strongly not recommended.

# INSTALLATION

## BATTERY AND CHARGING

Amplifiers will put an increased load on the vehicle's battery and charging system. We recommend checking your alternator and battery condition to ensure that the electrical system has enough capacity to handle the increased load of your stereo system. Stock electrical systems which are in good condition should be able to handle the extra load of any Lightning Audio amplifier without problems, although battery and alternator life can be reduced slightly. To maximize the performance of your amplifier, we suggest the use of a heavy duty battery and an energy storage capacitor.

## WIRING THE SYSTEM

 **CAUTION:** If you do not feel comfortable with wiring your new unit, please see your local Authorized Lightning Audio Dealer for installation.

 **CAUTION:** Before installation, disconnect the battery negative (-) terminal to prevent damage to the unit, fire and/or possible injury.

 **CAUTION:** Avoid running power wires near the low level input cables, antenna, power leads, sensitive equipment or harnesses. The power wires carry substantial current and could induce noise into the audio system.

1. Plan the wire routing. Keep RCA cables close together but isolated from the amplifier's power cables and any high power auto accessories, especially electric motors. This is done to prevent coupling the noise from radiated electrical fields into the audio signal. When feeding the wires through the firewall or any metal barrier, protect them with plastic or rubber grommets to prevent short circuits. Leave the wires long at this point to adjust for a precise fit at a later time.
2. Prepare the power cable for attachment to the amplifier by stripping 1/2" of insulation from the end of the wire. Insert the bared wire into the B+ terminal and tighten the set screw to secure the cable in place.

**NOTE:** The B+ cable **MUST** be fused 18" or less from the vehicle's battery. Install the fuseholder under the hood and prepare the cable ends as stated above. Connections should be water tight.

3. Trim the power cable within 18" of the battery and strip 1/2" of insulation from the end of the wire.
4. Strip 1/2" from the battery end of the power cable and crimp a large ring terminal to the cable. Use the ring terminal to connect to the battery positive terminal. **DO NOT install the fuse at this time.**
5. Prepare the grounding cable for attachment to the amplifier by stripping 1/2" of insulation from the end of the wire. Insert the bared wire into the GND terminal and tighten the set screw to secure the cable in place. Prepare the chassis ground by scraping any paint from the metal surface and thoroughly clean the area of all dirt and grease. Strip the other end of the wire and attach a ring connector. Fasten the cable to the chassis using a non-anodized screw and a star washer.
6. Prepare the REM turn-on wire for connection to the amplifier by stripping 1/2" of insulation from the wire end. Insert the bared wire into the REM terminal and tighten the set screw to secure the cable into place. Connect the other end of the REM wire to a switched 12 volt positive source. The switched voltage is usually taken from the source unit's accessory lead. If the source unit does not have this output available, the recommended solution is to wire a mechanical switch in line with a 12 volt source to activate the amplifier.
7. Securely mount the amplifier to the vehicle or amp rack. Be careful not to mount the amplifier on cardboard or plastic panels. Doing so may enable the screws to pull out from the panel due to road vibration or sudden vehicle stops.
8. Connect the source signal to the amplifier by plugging the RCA cables/high level inputs into the input jacks at the amplifier.

# INSTALLATION

- Connect the speakers. Strip the speaker wires 1/2" and insert into the speaker terminal and tighten the set screw to secure into place. Be sure to maintain proper speaker polarity. DO NOT chassis ground any of the speaker leads as unstable operation may result.
- Perform a final check of the completed system wiring to ensure that all connections are accurate. Check all power and ground connections for frayed wires and loose connections which could cause problems.

**NOTE:** Follow the diagrams for proper signal polarity.

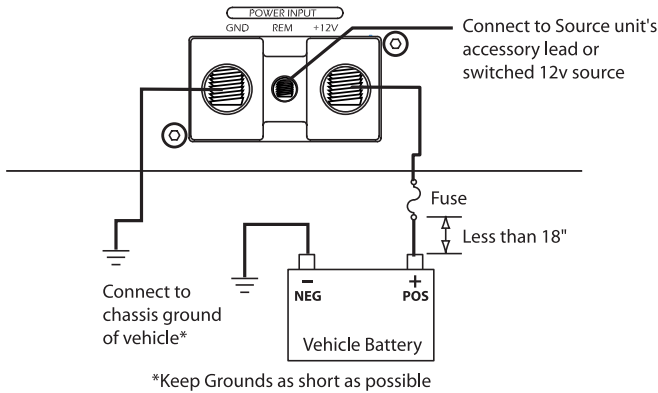

**CAUTION:** Use only one input configuration. Using both the RCA and High Level inputs will cause undesirable operation.

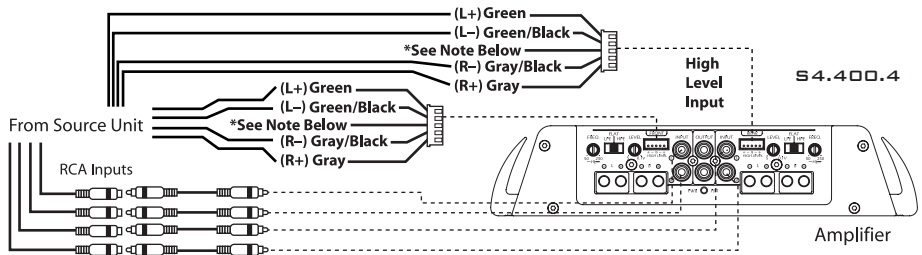
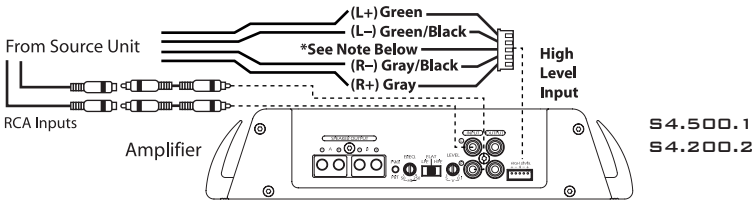

**\*NOTE:** When using High Level Inputs, if audible engine noise is present, connect the Black wire to chassis ground. If noise is still present, contact your local authorized dealer or Lightning Audio customer service.

# INSTALLATION

**NOTE:** Mono amplifier speaker outputs (A & B) are wired in parallel internally.

## Mono S4.500.1 (Note: The S4.500.1 is NOT 1 Ω stable.)

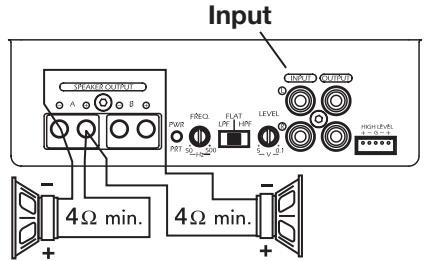
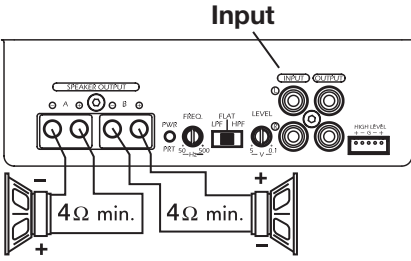

## Mono S4.1000.1D

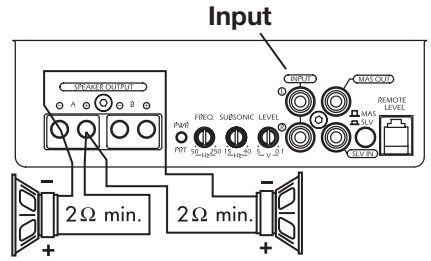
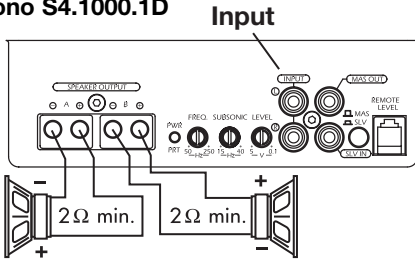

## 2-Channel

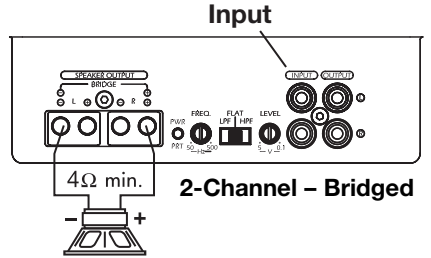
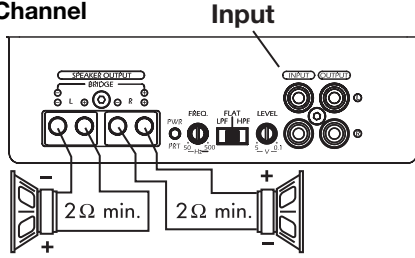

## 4-Channel

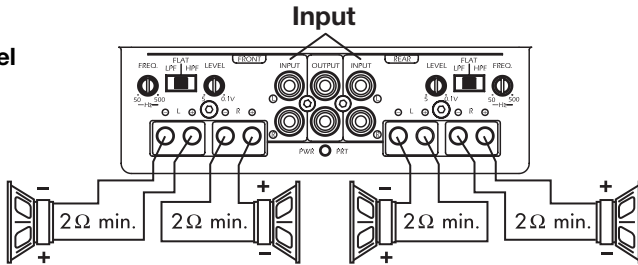

## 4-Channel - Set as 3-Channel Bridged

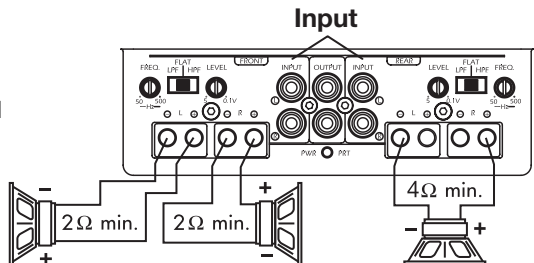

# INSTALLATION

## REMOTE LEVEL CONTROL (only usable in LP Low Pass mode) (Model S4.1000.1D Only)

### Mounting and installation

1. Find a location, either under the dash or near the center console, that gives easy access to the remote.
2. Using the screws supplied, install the mounting clip with the tabs towards the back.
3. Route the cable for the remote and connect to both the remote and amplifier.
4. Slip the remote onto the mounting clip until it snaps into place.

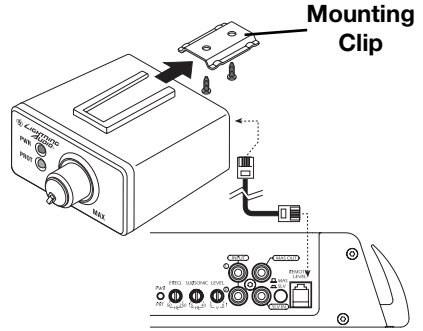

## USING PASSIVE CROSSOVERS

A passive crossover is a circuit that uses capacitors and/or coils and is placed on speaker leads between the amplifier and speaker. The crossover delegates a specific range of frequencies to the speaker for optimum driver performance. A crossover network can perform one of three functions: High-Pass (capacitors), Low-Pass (inductors or coils) and Bandpass (combination of capacitor and coil).

The most commonly used passive crossover networks are 6dB/octave systems. These are easy to construct and require one component per filter. Placing this filter in series with the circuit will reduce power to the speaker by 6dB/octave above or below the crossover point depending on whether it is a high-pass or low-pass filter. More complex systems such as 12dB/octave or 18dB/octave can cause impedance problems if not professionally designed.

Passive crossovers are directly dependent upon the speaker's impedance and component value for accuracy. When passive crossover components are used in multiple speaker systems, the crossover's effect on the overall impedance should be taken into consideration along with the speaker's impedance when determining amplifier loads.

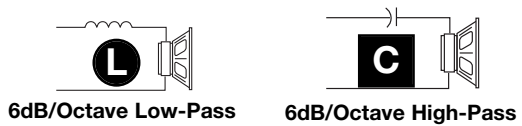

Freq. Hertz	Speaker Impedance					
	2 OHMS		4 OHMS		8 OHMS	
	L	C	L	C	L	C
80	4.1mH	1000µF	8.2mH	500µF	16mH	250µF
100	3.1mH	800µF	6.2mH	400µF	12mH	200µF
130	2.4mH	600µF	4.7mH	300µF	10mH	150µF
200	1.6mH	400µF	3.3mH	200µF	6.8mH	100µF
260	1.2mH	300µF	2.4mH	150µF	4.7mH	75µF
400	.8mH	200µF	1.6mH	100µF	3.3mH	50µF
600	.5mH	136µF	1.0mH	68µF	2.0mH	33µF
800	.41mH	100µF	.82mH	50µF	1.6mH	26µF
1000	.31mH	78µF	.62mH	39µF	1.2mH	20µF
1200	.25mH	66µF	.51mH	33µF	1.0mH	16µF
1800	.16mH	44µF	.33mH	22µF	.68mH	10µF
4000	.08mH	20µF	.16mH	10µF	.33mH	5µF
6000	51mH	14µF	.10mH	6.8µF	.20mH	3.3µF
9000	34mH	9.5µF	68mH	4.7µF	.15mH	2.2µF
12000	25mH	6.6µF	51mH	3.3µF	100mH	1.6µF

**L = Low-Pass (Inductor)**

**C = High-Pass (Capacitor)**

**For more information, see your Authorized Lightning Audio Dealer.**

# OPERATION

## ADJUSTING LEVEL

To adjust the level setting, turn the amplifier levels all the way down. Turn the source unit volume up until distortion is audible and then turn it down a bit until the distortion is inaudible. This will be about two thirds all the way up on most source units. Next, turn the amplifier level setting until once again distortion is audible and then back it down until the distortion is inaudible.

**NOTE:** For a more in depth setting procedure, contact Lightning Audio Technical Support.

## ADJUSTING CROSSOVER (X-OVER)

### Model S4.1000.1D Only

Turn the crossover adjustment knob all the way down. With the system playing at normal listening level, turn the crossover adjustment knob up slowly until the desired crossover point is achieved.

### All Other Models

Placing the switch in the HIGH position sets the amplifier to the High Pass mode, enabling frequencies above the cut-off point to pass, adjustable between 50-500Hz.

Placing the switch in the FLAT position sets the amplifier to the All Pass mode, preventing any crossover adjustment, allowing all frequencies to pass..

Placing the switch in the LOW position sets the amplifier to the Low Pass mode, enabling frequencies below the cut-off point to pass, adjustable between 50-500Hz.

Turn the crossover adjustment knob all the way down. With the system playing, turn the crossover adjustment knob up slowly until the desired crossover point is achieved.

## SUBSONIC (Model S4.1000.1D Only)

A variable 15-40Hz high pass filter designed to prevent frequencies below the audio range from being applied to the subwoofer from the amplifier.

Set this to your personal preference while listening to the system.

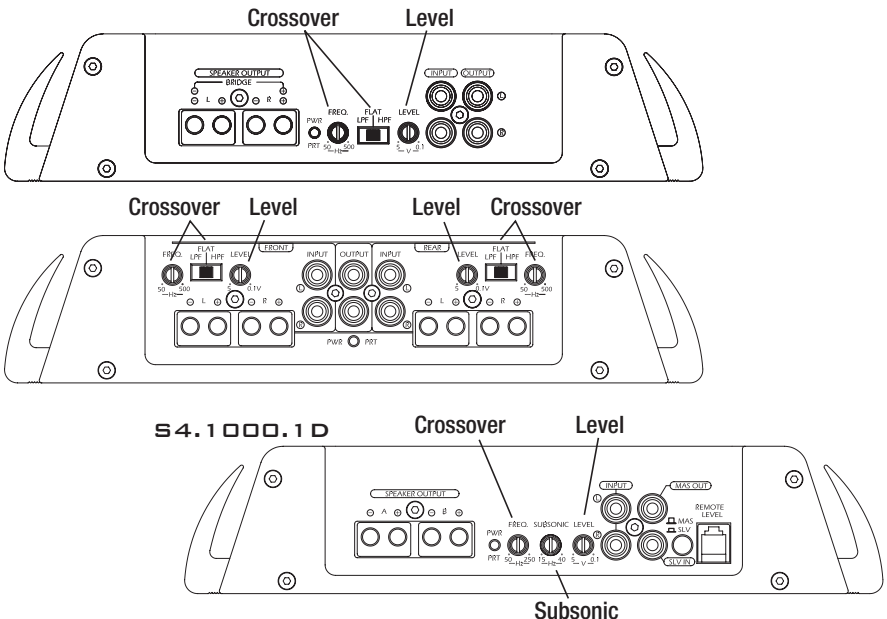

## OPERATION

### STRAPPING AMPLIFIERS (S4.1000.1D Only)

The S4.1000.1D amplifiers have the ability to connect two together and have their outputs combined, or strapped, to power a single speaker load.

**CAUTION:** Two S4.1000.1D amplifiers that are strapped together are not recommended for impedance loads below 2  $\Omega$ .

1. Select which amplifier of the two will be the master. and set the Master/Slave switch in the "out" position.

**NOTE:** Only adjustments made to the master amplifier will effect the output to the connected speaker.

2. Connect RCA cables from the source signal to the input connection on the master amplifier.
3. Set the Master / Slave switch on the slave amplifier to the "in" position.
4. Connect a RCA cable from the MAS OUT connector on the master amplifier to the SLV IN connector on the slave amplifier.
5. Connect one of the negative (-) speaker outputs from the master amplifier to one of the negative (-) speaker outputs on the slave amplifier using a 10 gauge wire (minimum).
6. Connect one of the positive (+) speaker outputs from the master amplifier to the positive (+) terminal of the speaker being use.
7. Connect one of the positive (+) speaker outputs from the slave amplifier to the negative (-) terminal of the speaker being use.

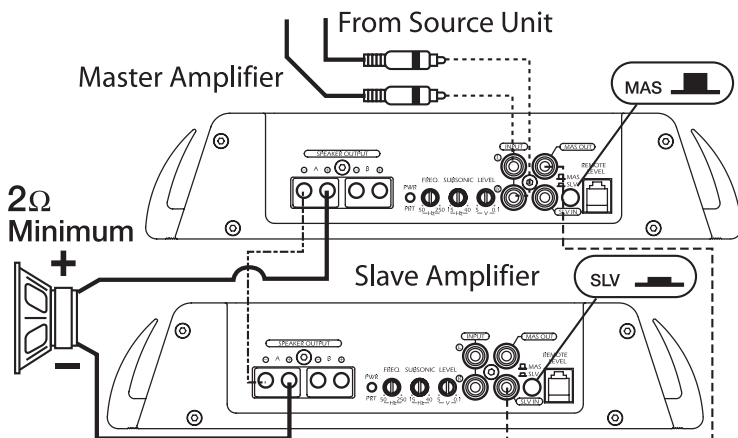

## TROUBLESHOOTING

Symptom	Diagnosis	Remedy
<b><i>Amplifier does not turn on.</i></b>	B+ or REM not between 10.5 and 15.5 volts or no voltage present	Check the alternator, battery, fuse, and wiring and repair as necessary
<b><i>Amplifier Noise</i></b>	Amplifier is not properly grounded.	Check wiring and repair as necessary
<b><i>(Turn-On Pop)</i></b>	Voltage spike from source unit is entering amplifier's input	Connect a relay turn-on module to REM terminal if pops are eliminated with no input signal to amplifier
<b><i>Engine Noise</i></b>	Noise is radiating into signal cables	Re-route signal cables away from sources of high current

# SPECIFICATIONS

MODEL- Strike	S4.500.1	S4.1000.1D	S4.200.2
<b>Continuous Power Rating (RMS) - Measured at 14.4 Battery Volts</b>			
4 Ω Load Per Channel	300 Watts x 1	250 Watts x 1	50 Watts x 2
2 Ω Load Per Channel	500 Watts x 1	500 Watts x 1	100 Watts x 2
4 Ω Load Bridged (Mono)			200 Watts x 1
S4.1000.1D Only-1 Ω Load		1000 Watts x 1	
Amplifier Fuse Rating (Amp/Type)	(2) 30A / AWG	(3) 30A / AWG	(1) 30A / AWG
Dimensions:			
Height	2.0" (5.08cm)	2.0" (5.08cm)	2.0" (5.08cm)
Width	10.5" (26.67cm)	10.5" (26.67cm)	10.5" (26.67cm)
Length	12.25" (31.11cm)	15.75" (40.00cm)	8.25" (47.24cm)

MODEL- Strike	S4.400.2	S4.600.2	S4.400.4	S4.600.4S
<b>Continuous Power Rating (RMS) - Measured at 14.4 Battery Volts</b>				
4 Ω Load Per Channel	100 Watts x 2	150 Watts x 2	50 Watts x 4	60 Watts x 2 <b>F</b> 125 Watts x 2 <b>R</b>
2 Ω Load Per Channel	200 Watts x 2	300 Watts x 2	100 Watts x 4	100 Watts x 2 <b>F</b> 200 Watts x 2 <b>R</b>
4 Ω Load Bridged (Mono)	400 Watts x 1	600 Watts x 1	200 Watts x 2	200 Watts x 1 <b>F</b> 400 Watts x 1 <b>R</b>
Amplifier Fuse Rating (Amp/Type)	(2) 30A / AWG	(2) 40A / AWG	(2) 30A / AWG	(2) 40A / AWG
Dimensions:				
Height	2.0" (5.08cm)	2.0" (5.08cm)	2.0" (5.08cm)	2.0" (5.08cm)
Width	10.5" (26.67cm)	10.5" (26.67cm)	10.5" (26.67cm)	10.5" (26.67cm)
Length	12.25" (31.11cm)	15.75" (40.00cm)	12.25" (31.11cm)	15.75" (40.00cm)

Signal-to-Noise Ratio	>70dB A-weighted
Input Sensitivity	100mV - 5V
Crossover (S4.1000.1D only)	12dB/octave Low Pass only
Crossover	12dB/octave High/Flat/Low Switch
Crossover Frequency (S4.1000.1D only)	variable from 50Hz to 250Hz, Low Pass Only
Crossover Frequency	variable from 50Hz to 500Hz
Channel Separation	50dB
Subsonic Filter (S4.1000.1D only)	Variable 15 - 40Hz

**NOTE: Staggered Power (S4.600.4S Only)** - Two separate power supplies with two separate output sections for the front and rear channels. In essence, it is 2 completely separate amplifiers sharing the same chassis. More power is created on the rear channels to allow the performance to be delivered where it is needed most.

---

## MODEL- Strike **S4.1000.1D (2 amplifiers strapped together)**

**Continuous Power Rating (RMS) - Measured at 14.4 Battery Volts**

4 Ω Load	1000 Watts x 1
2 Ω Load	2000 Watts x 1

**Specifications subject to change without notice**

# LIMITED WARRANTY INFORMATION

Lightning Audio offers a limited warranty on products on the following terms:

- **Length of Warranty**

**Speakers**

One year parts and labor warranty. Requires proof of purchase.

**Amplifiers**

One year parts and labor warranty. Requires proof of purchase.

**Bolt:** One year parts and labor warranty. Requires proof of purchase.

**Strike:** One year parts and labor warranty. Requires proof of purchase.

Or, Two years parts and labor warranty if installed by a Authorized Dealer. Requires proof of purchase.

- **What is Covered**

This warranty applies only to Lightning Audio products sold to consumers by Authorized Lightning Audio Dealers in the United States of America or its possessions. Product purchased by consumers from an Authorized Lightning Audio Dealer in another country are covered only by that country's Distributor and not by Lightning Audio.

- **Who is Covered**

This warranty covers only the original purchaser of Lightning Audio product purchased from an Authorized Lightning Audio Dealer in the United States. In order to receive service, the purchaser must provide Lightning Audio with a copy of the receipt stating the customer name, dealer name, product purchased and date of purchase.

- Products found to be defective during the warranty period will be repaired or replaced (with a product deemed to be equivalent) at Lightning Audio's discretion.

- **What is Not Covered**

1. Damage caused by accident, abuse, improper operations, water, theft, shipping
2. Any cost or expense related to the removal or reinstallation of product
3. Service performed by anyone other than Lightning Audio or an Authorized Lightning Audio Service Center
4. Any product which has had the serial number defaced, altered, or removed
5. Subsequent damage to other components
6. Any product purchased outside the U.S.
7. Any product not purchased from an Authorized Lightning Audio Dealer

- **Limit on Implied Warranties**

Any implied warranties including warranties of fitness for use and merchantability are limited in duration to the period of the express warranty set forth above. Some states do not allow limitations on the length of an implied warranty, so this limitation may not apply. No person is authorized to assume for Lightning Audio any other liability in connection with the sale of the product.

- **How to Obtain Service**

Please call 1-888-881-8186 for Lightning Audio Customer Service. You must obtain an RA# (Return Authorization number) to return any product to Lightning Audio. You are responsible for shipment of product to Lightning Audio. Always include Proof of Purchase.

**Mark RA# on outside of shipping carton.**

- **EU Warranty**

This product meets the current EU warranty requirements, see your Authorized dealer for details.

Ship to: **Electronics**  
Lightning Audio  
Warranty Repair Department  
2055 E. 5th Street  
Tempe, AZ 85281  
RA#: \_\_\_\_\_

Ship to: **Speakers**  
Lightning Audio  
Speaker Returns  
3056 Walker Ridge Dr. Suite G  
Walker, MI 49544  
RA#: \_\_\_\_\_



**Lightning Audio**

955 N. Fiesta Blvd, Suite 4  
Gilbert, Arizona 85233 U.S.A.  
In U.S.A., (480) 966-8278  
In Europe, Fax (49) 850-3934-014  
In Japan, Fax (81) 559-79-1265